

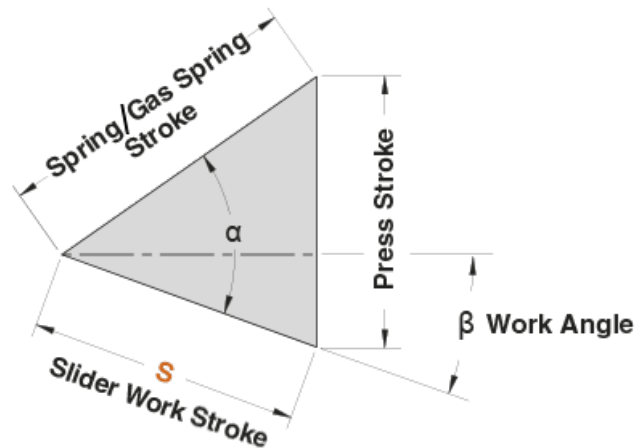

1. CAM DIAGRAM

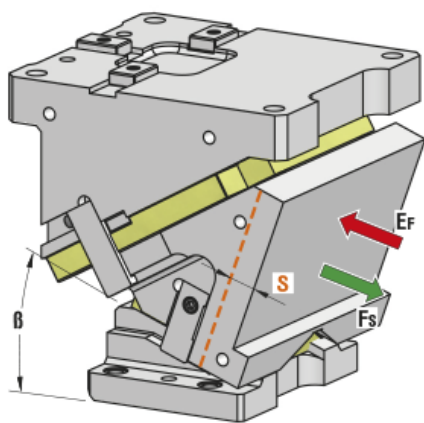

OMCR CODE	Work Angle β	Slider Work Stroke S (mm)	Press Stroke (mm)	Spring / Gas Spring Stroke (mm)	$\alpha - \beta$	α
CLB300.00	0°	38,57	45,96	60	50°	50°
CLB300.05	5°	42,59	46,14	60	45°	50°
CLB300.10	10°	46,67	46,67	60	40°	50°
CLB300.15	15°	50,88	47,58	60	35°	50°
CLB300.20	20°	55,30	48,91	60	30°	50°
CLB300.25	25°	60,00	50,71	60	25°	50°
CLB300.30	30°	65,10	53,07	60	20°	50°
CLB300.35	35°	70,75	56,11	60	15°	50°
CLB300.40	40°	77,13	60,00	60	10°	50°
CLB300.45	45°	84,53	65,00	60	5°	50°
CLB300.50	50°	93,34	71,51	60	0°	50°
CLB300.55	55°	104,61	85,69	60	0°	55°
CLB300.60	60°	120,00	103,92	60	0°	60°



2. WORK FORCE DISTRIBUTION (kN) FOR 1 MILLION CYCLES

The following diagrams illustrate the maximum possible ranges of camforce applicable in several portions of the work area but always working in the exact direction of slider work stroke. If several forces are applied simultaneously on the work area, their common center has to be specified and compared with the tabular infos. The sum of all forces has to be lower than the corresponding tabular value.



Max Work Force with shoulder



Max Work Force with fitting keys

Assembly with shoulder

		WIDTH					
		60	60	60	60	60	
HEIGHT	$\beta=0^\circ\div 60^\circ$	60	78	144	318	144	78
	60	104	195	411	195	104	
	60	89	156	371	156	89	
	60	89	156	371	156	89	

Assembly with fitting keys

		WIDTH					
		60	60	60	60	60	
HEIGHT	$\beta=0^\circ\div 60^\circ$	60	35	65	159	65	35
	60	47	88	205	88	47	
	60	40	70	185	70	40	
	60	40	70	185	70	40	